

JDN PROFI Air Hoists

J.D. Neuhaus manufactures high quality, superior PROFI Air Hoists which are known for their robust designs. This makes their products suitable for tough industrial applications, even in continuous working processes. Safety features, as 100% duty rating and explosion protecting, are an important advantage for applications in hazardous areas.



Features:

- Manufactured in Germany, under strict quality control with demanding tolerances.
- All JDN models are manufactured to comply with AS1418.2.
- Patented pre-lube motor design for low maintenance, oil-free operation.
- 100% duty rating and unlimited duty cycle suits all environmental conditions.
- Only six atmospheres of compressed air required.
- Insensitive to dust, humidity and temperatures ranging from -20 °C up to + 70 °C.
- ATEX-approved models available, suitable for application in dangerous and explosive environments
- Self-cooling economic air motor which will not overheat.
- Fail-safe brake, in case of air supply failure.
- From 1 tonne upwards available with overload protection.
- Low decibel rating.
- F-type sensitive infinitely variable speed control for the precise positioning of loads.
- Cord control or Brass Pendant control available, as well as an electro pneumatic interface for Radio Remote control as an option.
- Easy operation and low maintenance design.

The information shown is to be used as a guide only. Specifications are subject to change without notice. All materials handling or lifting jobs should be assessed individually. Pacific Hoists products are NOT to be used for lifting or lowering persons.

Specifications

Model	0.25Ti	0.5Ti	1Ti	1.5Ti	2Ti	3Ti
Stock Code	JDN705	JDN706	JDN715	JDN719	JDN725	JDN735
Rated Capacity (tonne)	0.25	0.5	1	1.6	2	3.2
Weight with Standard 3m lift (m)	27	27	28	56	34	86
No. of Chain Strands	1	1	1	1	2	1
Motor Power (kW)	1.0	1.0	1.0	1.3 - 2	1.0	3.5
Chain Dimension (mm)	7 x 21	7 x 21	7 x 21	9 x 27	7 x 21	13 x 36
Air Pressure (bar)	6	6	6	4 - 6	6	6
Air Consumption at full load (m ³ /min)						
Lifting	1.2	1.2	1.2	1.5 - 2.6	1.2	4
Lowering	1.5	1.5	1.5	2.2 - 3.6	1.5	5.5
Air Connection	G½	G½	G½	G¾	G½	G¾
Lifting Speed at Full Load (m/min)	20	11	5.5	4 - 6	2.7	5
Lowering Speed at Full Load (m/min)	38	17	11	11 - 12	5.5	10.8

Model	3Ti/2	6Ti	10Ti	16Ti	20Ti
Stock Code	JDN732	JDN765	JDN775	JDN785	JDN795
Rated Capacity (tonne)	3.2	6.3	10	16	20
Weight with Standard 3m lift (m)	66	110	156	240	285
No. of chain strands	2	2	2	3	4
Motor Power (kW)	1.3 - 2	3.5	3.5	3.5	3.5
Chain Dimension (mm)	9 x 27	13 x 36	16 x 45	16 x 45	16 x 45
Air Pressure (bar)	4 - 6	6	6	6	6
Air Consumption at Full Load (m ³ /min)					
Lifting	1.5 - 2.6	4	4	4	4
Lowering	2.2 - 3.6	5.5	5.5	5.5	5.5
Air Connection	G¾	G¾	G¾	G¾	G¾
Lifting Speed at Full Load (m/min)	2 - 3	2.5	1.6	1	0.7
Lowering Speed at Full Load (m/min)	5.5 - 6	5.4	3.4	2.1	1.6

*PROFI Range available up to 100 tonne.

**Chain buckets, longer lift heights and alternative controllers available at additional cost.

***Weight and headroom based on PROFIT standard model with rope control and no chain bucket.

The information shown is to be used as a guide only. Specifications are subject to change without notice. All materials handling or lifting jobs should be assessed individually. Pacific Hoists products are NOT to be used for lifting or lowering persons.

Dimensions (in mm)

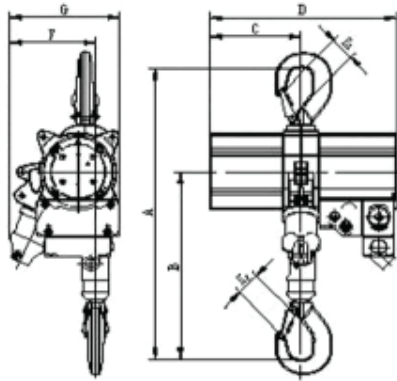

PROFI 0.25Ti - 2Ti

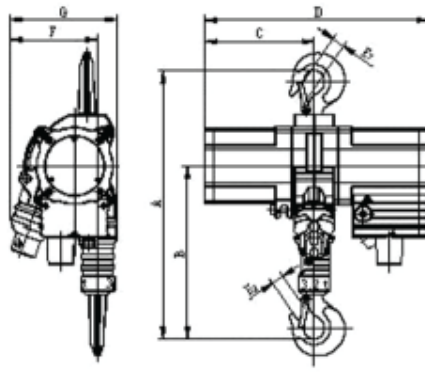

PROFI 1.5Ti - 3Ti/2

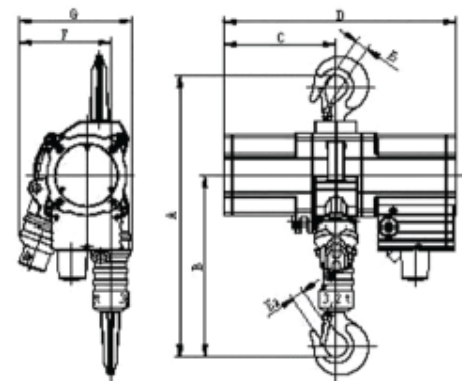

PROFI 3Ti / 20Ti

Model	0.25Ti	0.5Ti	1Ti	1.5Ti	2Ti	3Ti	3Ti/2	6Ti	6Ti	10Ti	16Ti	20Ti
A (min. headroom¹)	450	450	450	480	498	593	544	674	674	813	898	1030
B	288	288	288	293	336	373	356	454	454	598	598	670
C	145	145	145	200	145	233	200	233	233	382	382	382
D	297	297	297	412	297	483	412	483	483	692	692	692
E1	28	28	28	28	28	40	28	40	40	53	53	75
E2	28	28	28	26	28	30	28	40	40	53	53	75
F (Up to hook centre)	137	137	137	170	137	187	140	154	154	199	199	180
G (max. width)	176	176	176	215	183	233	215	233	233	308	308	315

¹Chain buckets increase the hoist headroom

Sydney - Head Office

24 Foundry Road
Seven Hills, NSW 2147
Australia

☎ +61 (0)2 8825 6900

☎ +61 (0)2 8825 6999

Western Australia

8 Monash Gate
Jandakot, WA 6164
Australia

☎ +61 (0)8 6253 1000

☎ +61 (0)8 9458 9840

Auckland NZ

11 Druces Road
Wiri, Auckland 2104
New Zealand

☎ +64 (0)9 263 5566

☎ +64 (0)9 263 5567

