



Home > ETF50 - Electric Scissor Lift

ETF50 - ELECTRIC SCISSOR LIFT



Condition: New product

Industrial Quality Equipment used across many industries. Designed and Manufactured to meet the highest demand applications industries have to offer.

Quantity

1



Electric Lifting, Great for loads up to 500kg.

MORE INFO

NOBLELIFT

- ✓ Electric lifting
- ✓ Great for loads up to 500kg
- ✓ Outstanding lift and lowering speeds
- ✓ Lifts to over 1m

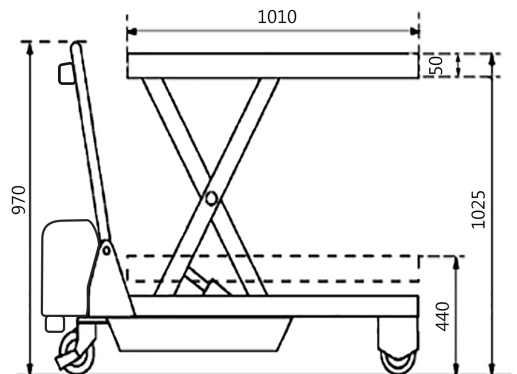



DATA SHEET

Model	ETF 50
Capacity (kg)	500
Table height range (mm)	440-1025
Dimensions of table (mm)	1010 X 520 X 50
Castor Wheel (mm)	150 X 48
N.W (kg)	157
Handle Height from ground (mm)	970



PRECISION HYDRAULIC PUMP

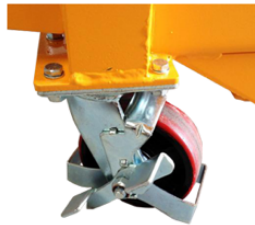

LOCKABLE WHEELS



ELECTRIC LIFT