



## **SWING LIFT**    **NEW!**

**MODEL:** AL-SW500

Light weight, robust construction and ease of use combine to provide users with a versatile and effective load handling tool.

### **FEATURES**

- Lightweight and portable
- Manufactured from high strength aluminium
- Lifts 500kg in all positions
- Robust construction
- Self contained within a carry bag for ease when working on remote sites
- Helps prevent the risk of injury through manual handling and working over deep wells
- Adjustable from 565-1100mm

### **OPTIONS**

- 12 or 24v hoist with built in overload protection
- Boom extension with up to 1900mm reach
- Extra rope length - up to 50'/16m
- Overload device
- Lifting accessory kit

## APPLICATIONS

- Highway maintenance work
- Construction Site
- Council and  
Local authorities work
- Local authorities
- Tyre industry

### Weights & measurements

Winch 22kg

Base 12kg

Upper crane section 4.2kg

Turnbuckle 2.3kg

Optional:

Boom & winch 13kg

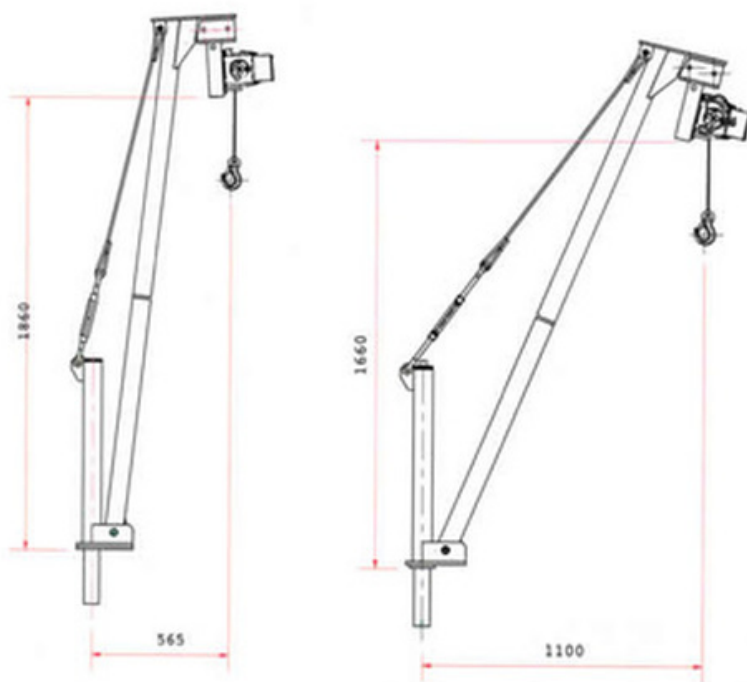

Optional version  
with extended boom

