



Home TF15 - 150kg Scissor Lift

TF15 - 150KG SCISSOR LIFT



Condition: New product

Industrial Quality Equipment used across many industries. Designed and Manufactured to meet the highest demand applications industries have to offer.

Quantity



Positive braking system on rear wheels for safety. Handle folds flat for easy storage.

MORE INFO

NOBLELIFT

- ✓ Lightweight and manouverable
- ✓ 150kg capacity
- ✓ Manual Push
- ✓ Precision hydraulic foot pump
- ✓ Quick release system

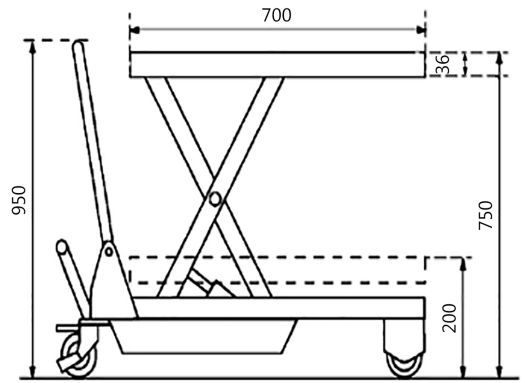

DATA SHEET

Model	TF 15
Capacity (kg)	150
Table height range (mm)	220-750
Dimensions of table (mm)	700 X 450 X 36
Castor Wheel (mm)	100 X 25
N.W (kg)	49
Handle Height from ground (mm)	950



PRECISION HYDRAULIC PUMP

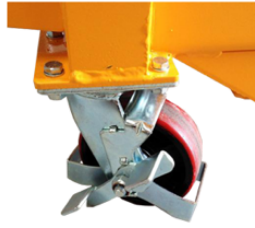

LOCKABLE WHEELS



FOOT PUMP