



[Home](#) > TF200 - 200kg Rough Terrain Scissor Lift

TF200 - 200KG ROUGH TERRAIN SCISSOR LIFT



Condition: New product

Industrial Quality Equipment used across many industries. Designed and Manufactured to meet the highest demand applications industries have to offer.

Quantity



- Foot operated
- Hydraulic lift
- Powdercoated finish
- Lever release control
- Lockable swivel castors

MORE INFO

NOBLELIFT

- ✓ Lightweight and manouverable
- ✓ 200kg capacity
- ✓ Manual Push
- ✓ Precision hydraulic foot pump
- ✓ Quick release system

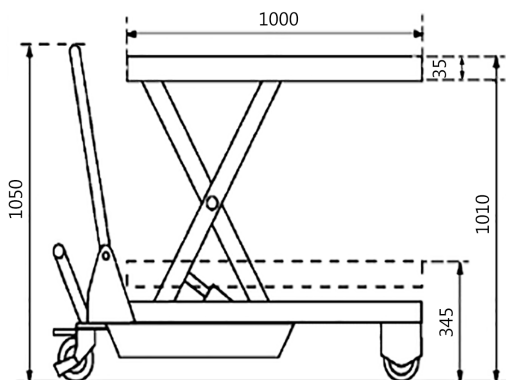

DATA SHEET

Model	TF 200
Capacity (kg)	200
Table height range (mm)	345-1010
Dimensions of table (mm)	1000 X 500 X 35
Castor Wheel (mm)	200
Weight (kg)	85
Handle Height from ground (mm)	1050



PRECISION HYDRAULIC PUMP



LOCKABLE WHEELS



FOOT PUMP