



[Home](#) >
 [Lifting & Handling Equip](#) >
 [Scissor Lift Tables](#) >
 TF50 - 500kg / TF30 - 300kg Scissor Lift Table

TF50 - 500KG / TF30 - 300KG SCISSOR LIFT TABLE



Condition: New product

Industrial Quality Equipment used across many industries. Designed and Manufactured to meet the highest demand applications industries have to offer.

Quantity

1



Overload valve ensures load limit is not exceeded.

MORE INFO

NOBLELIFT

- ✓ Positive braking system on rear wheels for safety
- ✓ Overload valve ensures load limit is not exceeded
- ✓ Manual Push
- ✓ Precision hydraulic foot pump

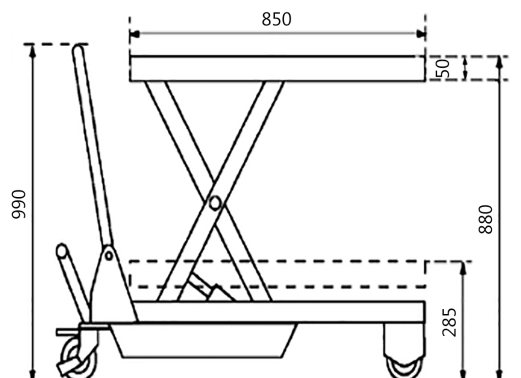

✓ Quick release system



DATA SHEET

Model	TF 50
Capacity (kg)	500
Table height range (mm)	285-880
Dimensions of table (mm)	850 X 500 X 50
Castor Wheel (mm)	125 X 40
N.W (kg)	81
Handle Height from ground (mm)	990



PRECISION HYDRAULIC PUMP

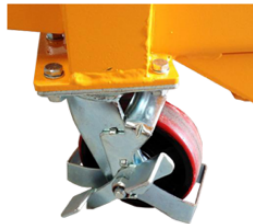

LOCKABLE WHEELS



FOOT PUMP